

UNCONTROLLED DOCUMENT

PART NUMBER
GT-RLSAE500

REV.
A

REV.	E.C.N. NUMBER AND REVISION COMMENTS	DATE
A	E.C.N. #11148.	12.19.06

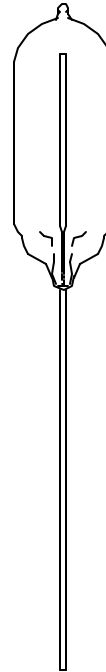
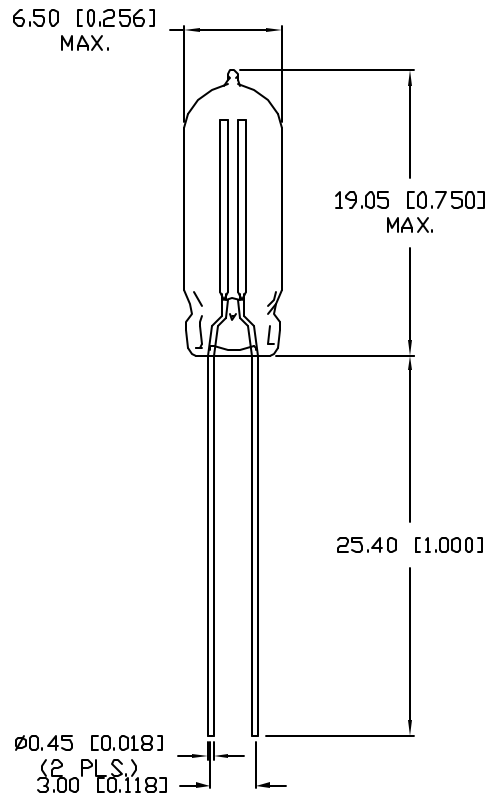

ELECTRICAL SPECIFICATIONS

CONDITION	SYMBOL	RATING
D.C. FIRING VOLTAGE:	{dv/dt 100V/S}	500±10% VDC
IMPULSE MAX. FIRING VOLTAGE:	{dv/dt 5KV/μS}	1500 VDC
IMPULSE CURRENT (KA):	{I/20μS}	1.5 KA MAX.
IMPULSE SURGE LIFE(X):	{I/20μS 500A}	1000 TIMES MIN.
D.C. HOLDOVER VOLTAGE:	{150ms MAX.}	50 V D.C.
A.C. DISCHARGE CURRENT:	{1S X 5 TIMES}	1 AMP
A.C. FOLLOW-ON CURRENT:	{1/2 CYCLE, 60Hz}	1 AMP
INSULATION RESISTANCE(MIN.):	{100VDC}	10 ⁸ Ω
INTER-ELECTRODE CAPACITANCE:	{1.0 KHz}	1.0 PF MAX.

ENVIRONMENTAL SPECIFICATIONS PER MIL-STD 202

TEST	METHOD	CONDITION	RATING
VIBRATION TESTING:	204B	C	C10-55Hz, .06DA
THERMAL SHOCK:	107	B	-65 TO +125°C
HUMIDITY:	103B	B	95% Re. HUMIDITY
TEMP CYCLING:	102A	C	-65 TO +125°C
SOLDERABILITY:	20B	B	
OPERATION TEMP.	-	-	-40 TO +100°C

RESPONSE TIME

SURGE TYPE	(Rt MAX.)
1Kv/mS	1 x 10 ⁻⁵ sec.
1Kv/μS	1 x 10 ⁻⁸ sec.
5Kv/μS	1 x 10 ⁻⁹ sec.



*UNLESS OTHERWISE SPECIFIED TOLERANCES PER DECIMAL PRECISION ARE: X=±1 (±0.039), XX=±0.5 (±0.020), XXX=±0.25 (±0.010), XXXX=±0.127 (±0.005). LEAD SIZE=±0.05 (±0.002), LEAD LENGTH=±0.75 (±0.030), MIN=+0.00/-0.00 DECIMAL PRECISION MAX.=+0.00/-0.00 DECIMAL PRECISION

UNCONTROLLED DOCUMENT

REV. A	PART NUMBER GT-RLSAE5000
-----------	-----------------------------

CONFIDENTIAL INFORMATION
THE INFORMATION CONTAINED IN THIS DOCUMENT IS THE PROPERTY OF LUMEX INC. EXCEPT AS SPECIFICALLY AUTHORIZED IN WRITING BY LUMEX INC, THE HOLDER OF THIS DOCUMENT SHALL KEEP ALL INFORMATION CONTAINED HEREIN CONFIDENTIAL AND SHALL PROTECT SAME IN WHOLE OR IN PART FROM DISCLOSURE AND DISSEMINATION TO ALL THIRD PARTIES.



290 E. HELEN ROAD
PALATINE, IL 60067-6976
PHONE: +1.847.359.2790
US WEB: www.lumex.com
TW WEB: www.lumex.com.tw

LIGHT DUTY RADIAL LEAD ARRESTOR, 500 VDC.

RELIABILITY NOTE
OUR MANY YEARS OF EXPERIENCE DATA ACCUMULATION INDICATE THAT SOLDER HEAT IS A MAJOR CAUSE OF EARLY AND FUTURE FAILURE. PLEASE PAY ATTENTION TO YOUR SOLDERING PROCESS.

DRAWN BY: JC	CHECKED BY:	APPROVED BY:	DATE: 12.09.06
			PAGE: 1 OF 1
			SCALE: N/A